

Firas Balasmeh Corporation For Control Systems

Corporation Profile

January 2023

Education & Training Solutions Business Line

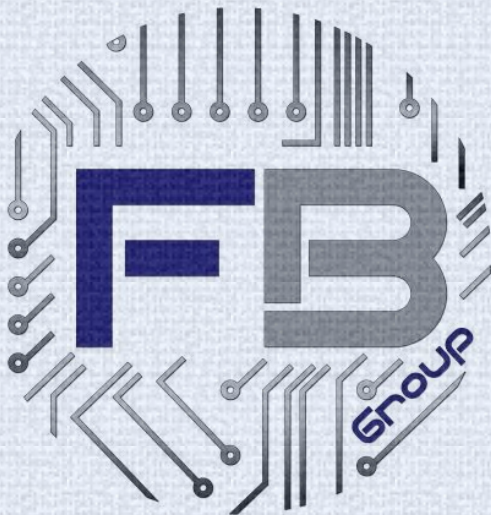

INTRODUCTION

ABOUT US...

Firas Balasmeh Corporation for Control Systems "FB GROUP", is a Jordanian individual corporation operating in Jordan since 2010.

FB GROUP is run by a professional team of well experienced and multi-disciplinary engineers. We work as a system integrator that provides services for business organizations and people to find quality vendors of reliable and high quality hardware, software, service, training & support.

Services provided are: Turnkey solutions, design, engineering, supplying, installation, commissioning, testing, training, and operation and maintenance.

INTRODUCTION

OUR VISION...

1

Provide the Kingdom of Jordan & the Middle East region based Supply, Engineering and Services to the Industrial & Commercial Sectors.

2

Develop the Kingdom of Jordan & the Middle East region based cores of Technology for improving the productivity and environmental compliance of Jordan & the ME region industries.

3

Enhance the viability of the Kingdom & the ME region installed systems, reduce life cycle costs and increase return on investment by enhanced support and technology transfer.

INTRODUCTION

OUR MISSION...

Continually exceed our customer's expectations as well as continually improve our capabilities in doing so.



OUR OBJECTIVE...

Our main OBJECTIVE is increasing the engineering support, services and training business.



INTRODUCTION

WHAT WE VALUE...

Integrity, Honesty and Fairness...

- We are a company that keeps its promises.

Customer Satisfaction...

- We exceed customer expectations through continuous improvement in quality, service, productivity and time compression.

Our Employees...

- We provide our people with the tools, training and support to achieve excellence in customer satisfaction.

Improvement & Innovation...

- Which we seek in every element of our business.

Social Responsibility...

- We actively recognize the central role we occupy in the structure of society to improve the quality of life and the environment of a broad community.

INTRODUCTION

WHAT WE DO...

Pre-Engineering

Design

Manufacturing

Integration

Upgrading

Installation

Support & Maintenance

Training

Auditing

INTRODUCTION

WHAT WE DO...

Pre-Engineering



- Building of existing drawings.
- Preparation of preliminary drawings.
- Bid packages.
- Assistance in evaluation of bids and bid verification.
- Reports on compliance.

Design



- Detailed Specification of a Proposed Solution.
- Detailed Design Preparation.
- Procurement Services.
- Design Verification.

Manufacturing



- Manufacturing of panels as per design documents.
- Wiring of Terminations, Isolation and I/O Cards.
- Preparation of systems, mounting of equipment.
- Testing.

INTRODUCTION

WHAT WE DO...

Integration



- Integration of Multiple Systems.
- Specification of Protocols and Communications.

Upgrading



- Modification to meet Process Changes.
- Hot Change Out.
- Re-Programming , Re-Configuration and Re-Tuning.
- Expansion of Control Systems .

Installation



- Installation and testing of our systems.
- Field Wiring.
- Termination.
- Demobilization of Equipment.
- Mobilization of New Equipment.

INTRODUCTION

WHAT WE DO...

Support & Maintenance



- Planned Maintenance.
- Preventive Maintenance.
- Spares Management Programs.

Training



- For all systems provided and supported by us.
- In House Training.
- Onsite Training.
- Maintenance Manuals.

Auditing



- Pre and post Audit of control systems.
- Financial evaluation of installations.
- Assessment of upgrade, modification & replacement costs.
- Techno Economic Analysis.

INTRODUCTION

OUR CORE BUSINESS LINES



Education & Training Solutions



EDUCATION & TRAINING SOLUTIONS

INTRODUCTION...

FB GROUP is dedicated to supplying, installing and commissioning of didactic engineering, medical and natural science equipment and laboratories.

We propose flexible systems that ensure maximum compliance with current state-of-the art technologies and the skills demands of local industrial markets.

The didactic equipment are meant to cover a wide range of the technology courses described in the curricula of universities and technical, vocational and medical institutes.

EDUCATION & TRAINING SOLUTIONS

OUR SERVICES...

(1) Pre-Sales

- Technical consultation.
- Pre-bid preparation.



(2) Supply

We are keen to provide the best solutions for our clients through a solid worldwide network of partners from different origins; USA, Europe, Korea and India.

EDUCATION & TRAINING SOLUTIONS

OUR SERVICES...

(3) Installation, Commissioning, Operation and Maintenance.

Performed at site by our well experienced and trained engineers.



(4) Training

Client's staff get trained on the newly installed equipment by our professional engineers, make sure that the client is capable to use and operate the equipment.

EDUCATION & TRAINING SOLUTIONS

OUR SOLUTIONS...

(1) ENGINEERING LABS

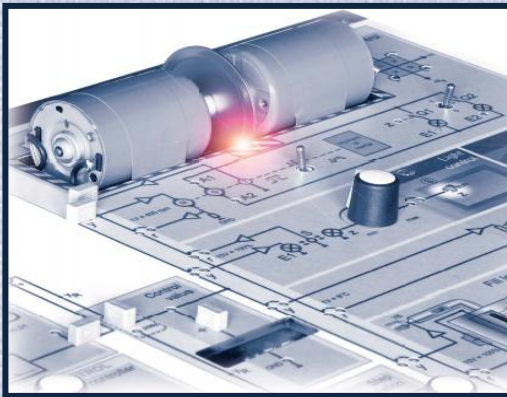

Electrical



Mechanical



Construction



Mechatronics

EDUCATION & TRAINING SOLUTIONS

OUR SOLUTIONS...

(2) NATURAL SCIENCE LABS



Chemistry



Biology



Physics

(3) TECHNOLOGY LABS



EDUCATION & TRAINING SOLUTIONS

OUR SOLUTIONS...

(4) MEDICAL LABS



Biomedical

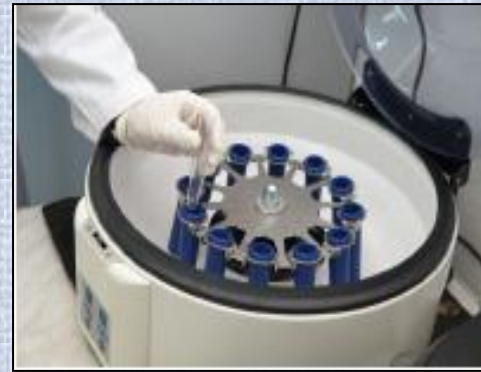

Testing

(5) E-LEARNING LABS



EDUCATION & TRAINING SOLUTIONS

OUR SOLUTIONS...

(6) VOCATIONAL TRAINING LABS



(7) TESTING AND MEASURING EQUIPMENT



EDUCATION & TRAINING SOLUTIONS

OUR CLIENTS...



EDUCATION & TRAINING SOLUTIONS

LIST OF EXECUTED PROJECTS ...

Year	Client	Capacity
2019 - 2021	Hashemite University	Structural systems lab equipment and devices
	University of Jordan	Civil lab equipment
	University of Jordan	Mechanical lab equipment
2019 - 2020	Hashemite University	Engineering Faculty labs equipment
	Mutah University	Medical lab equipment
	Jordan Meteorological Department	Barometers
2018	Al Hussein Technical University	Mechanics and hydraulics lab equipment
	Al Hussein Technical University	Construction technology lab equipment
2017	Al Hussein Technical University	Full automation lab consists of: <ul style="list-style-type: none"> – Basic learning center kits – GROOV, Remote Monitoring and Controlling >> Supplying, installation, commissioning, and training for staff engineers.
	Al Hussein Technical University	Full automation lab consists of: <ul style="list-style-type: none"> – Advanced and professional training kits – GROOV, Remote Monitoring and Controlling – Redundancy and networking applications – Energy monitoring unit kit >> Supplying, installation, commissioning, and training for staff engineers.
	Al Hussein Technical University	6 KW _p off-grid photovoltaic system (3 systems - 2 kW _p each: fixed tilt, single axis tracking and double axis tracking), for education and research. >> Supplying, installation, commissioning, and training for staff engineers.
	Al Hussein Technical University	Biology lab equipment

EDUCATION & TRAINING SOLUTIONS

LIST OF EXECUTED PROJECTS ...

Year	Client	Project
2014	The University of Jordan	Electrical meters laboratory
	The University of Jordan, Industrial Engineering Dept.	Full automation lab - Basic learning center kits >> Supplying, installation, commissioning and training for staff engineers.
	Jordanian Royal Medical Services	Ultrasonic nebulizer
2013	Jordan University for Science and Technology	Photovoltaic lab equipment
	The University of Jordan	Scientific devices and equipment
	Aal Al-Bayt University	Anatomy and physiology laboratory equipment
2012	Jordanian Royal Medical Services	Portable vascular hand held doppler
	Yarmouk University	Scientific devices and equipment
	Jordan University for Science and Technology	Science labs devices and equipment
2011	Ministry of Education, USAID	Biology labs equipment for 28 new schools
	German Jordanian University	Electronic circuits lab equipment

EDUCATION & TRAINING SOLUTIONS

CORPORATE SOCIAL RESPONSIBILITY

We are committed to improve university students and fresh graduates' technical skills and experience by providing latest technology equipment compatible with the outside markets, giving them confidence to fulfill employers needs and better employment opportunities.

Donations

8,000 \$	<ul style="list-style-type: none">• Two Biology Labs• Hussein Technical University
14,000 \$	<ul style="list-style-type: none">• Electrical Lab• University of Jordan
42,000 \$	<ul style="list-style-type: none">• Industrial Automation Lab• University of Jordan
150,000 \$	<ul style="list-style-type: none">• Industrial Automation Labs (Basic & Advance)• Hussein Technical University
44,000 \$	<ul style="list-style-type: none">• 12 Biology Labs• Different Public and Private Schools

SUMMARY

OUR ADVANTAGES

- Diversity of business. We provide our solutions in many different sectors and capable to perform the best among others, having the best confident capacities and abilities.
- Having the most powerful political relations and influences in the Kingdom with both private and public sectors, coming from our diversity of business during the past years.
- Having a powerful financial situation built during the past years with especially with our financial partners and developers.
- Being an agent and a distributor for many reputable manufacturers.
- Commitment, trustable and comfortable to deal with.
- Providing innovation and customer satisfaction.
- Providing highly reputable and well established brands which cater to the exact requirement of clients, within budget and on-time.

WE AT FB GROUP...

Strongly Believe that We Have the Capabilities, Knowledge and Strength to Satisfy Our Client's Requirements and Exceed Their Expectations...

SUMMARY

OUR ADVANTAGES

- Diversity of business. We provide our solutions in many different sectors and capable to perform the best among others, having the best confident capacities and abilities.
- Having the most powerful political relations and influences in the Kingdom with both private and public sectors, coming from our diversity of business during the past years.
- Having a powerful financial situation built during the past years with especially with our financial partners and developers.
- Being an agent and a distributor for many reputable manufacturers.
- Commitment, trustable and comfortable to deal with.
- Providing innovation and customer satisfaction.
- Providing highly reputable and well established brands which cater to the exact requirement of clients, within budget and on-time.

WE AT FB GROUP...

Strongly Believe that We Have the Capabilities, Knowledge and Strength to Satisfy Our Client's Requirements and Exceed Their Expectations...